

Viking CCS Pipeline

**Environmental
Statement Volume IV –
Appendix 10-1 Outline
Soil Management Plan –
Revision B (Clean)**

Document Reference: EN070008/APP/6.4.10.1

Applicant: Chrysaor Production (U.K.) Limited,
a Harbour Energy Company
PINS Reference: EN070008
Planning Act 2008 (as amended)
The Infrastructure Planning (Applications: Prescribed Forms
and Procedure) Regulations 2009 - Regulation 5(2)(a)
Date: September 2024

PINS Reference	Document Reference	Document Revision	Date
EN070008	EN070008/APP/6.4.10.1	Revision 1	October 2023
EN070008	EN070008/APP/6.4.10.1	Revision A	May 2023
EN070008	EN070008/APP/6.4.10.1	Revision B	August 2023

Prepared by	Verified by	Approved by
HS	MW	NP
Environment Associate Director	EIA Technical Director	EIA Technical Director

Prepared by:

AECOM Limited
Exchange Station
Tithebarn Street
Liverpool
Merseyside
L2 2QP

© AECOM Limited. All rights reserved.

Table of Contents

1	Outline Soil Management Plan	1
1.1	Introduction.....	1
1.2	Glossary of Terms.....	2
1.3	Roles and Responsibilities.....	3
1.4	Limitations of use of the Outline SMP.....	5
2	Review and update of the Outline SMP.....	6
3	Soil Resources	7
3.1	Overview.....	7
3.2	Soils at Low Risk of Damage.....	11
3.3	Soils at Medium Risk of Damage.....	11
3.4	Soils at High Risk of Damage or High Risk of Erosion	11
4	Good Practice Mitigation	16
4.1	General principles of soil handling.....	16
4.2	Stop Conditions	17
4.3	Field testing of soil conditions.....	18
4.4	Soil Preparation	20
4.5	Soil Stripping	21
4.6	Soil Stripping for Archaeological Works.....	22
4.7	Stockpiles	23
4.8	Stockpile Maintenance	25
4.9	Stockpile Records.....	26
4.10	Access along pipe trenches.....	26
4.11	Drainage.....	27
4.12	Restoration	27
4.13	Aftercare.....	30
5	Biosecurity.....	31
6	Additional Mitigation and Enhancement Measures.....	31
7	Monitoring Schedule.....	33
8	References	34

Figures

Figure 1: Spatial Extent of Soil Sensitivity.....	8
---	---

Plates

Plate 1: Stripping with excavators and dump trucks: removal of topsoil from a strip. Reproduced from Part 2: Sheet A of IoQ (2021) (Ref. 3).....	22
Plate 2: Stripping with excavators and dump trucks: removal of subsoil from a strip. Reproduced from Part 2: Sheet A of IoQ (2021) (Ref. 3).....	23
Plate 3: Soil storage mound construction with excavators and dump trucks. Reproduced from Part 2: Sheet B of IoQ (2021) (Ref. 3).	25

Plate 4: Excavation of soil storage mound with excavators and dump trucks.
Reproduced from Part 2: Sheet C of IoQ (2021) (Ref. 3). 28

Tables

Table 1: Soil Associations in the DCO Site Boundary 12
Table 2: Testing for Soil Moisture State 19
Table 3: Testing for Soil Consistency 20
Table 4: Record keeping and monitoring during the construction phase 33

1 Outline Soil Management Plan

1.1 Introduction

- 1.1.1 This is the second revision of the Outline Soil Management Plan (SMP). The first revision addressed comments received from Natural England on 26 April 2024 in their Written Representations (Version 1.1) in respect of Viking CCS Pipeline DCO Examination (Deadline 1). This second revision seeks to address comments within Natural England's Response to 'Applicant's Comments on Written Representations' and reflect the outcomes of a meeting with Natural England on 9 July 2024 in which Natural England's requirements were clarified and an approach agreed.
- 1.1.2 The Outline SMP sets out principles and procedures for good practice (embedded mitigation measures) and bespoke mitigation measures in soil handling, storage and reinstatement to be used for the Viking CCS Pipeline (hereafter referred to as the Proposed Development). This Outline SMP sets out framework that the appointed Contractor will follow to minimise adverse effects on soil resources.
- 1.1.3 To secure effective delivery of the Outline SMP, it must be implemented (by the Contractor) through site-specific soil management method statements (or similar) for the construction phase. The works must also be monitored to audit compliance with the Outline SMP (and location-specific construction method statements); and to allow ongoing advice on soil management to be provided.
- 1.1.4 The Outline SMP is based upon guidance such as the Department for Environment, Food and Rural Affairs' (Defra) Construction Code of Practice for the Sustainable Use of Soils on Construction Sites (Ref. 1); the Ministry of Agriculture Fisheries and Food's (MAFF) Good Practice Guide to Handling Soils (Ref. 2) and its update the Institute for Quarrying's (IoQ) Good Practice Guide for Handling Soils in Mineral Workings (Ref. 3), and the consultant's experience. It is noted that although the IoQ guide is titled for use in mineral workings, it is applicable to all infrastructure projects, particularly those where large volumes of soil are to be stripped, stored, and reinstated, such as linear infrastructure projects like the Proposed Development.
- 1.1.5 The Outline SMP assumes that all mitigation measures pertaining to protected species and other environmental issues are in place, such that the soil stripping, storage and reinstatement operations can proceed.
- 1.1.6 The Outline SMP will be revised (to the Detailed SMP) prior to commencement of construction operations and will be updated with data/information provided through detailed pre-construction soil surveys. These pre-commencement soil and Agricultural Land Classification (ALC) surveys will incorporate all land which will be subject to direct disturbance, and which has yet to be subject to a detailed soil survey. Not only will this data aid in the production and implementation of the Detailed SMP, but it will also provide baseline land quality data for the reinstatement of land within the proposed working area of the pipeline route. The detailed SMP is to be considered a 'live document' to be updated should further information become available.

1.2 Glossary of Terms

1.2.1 The following definitions are provided to aid understanding of the Outline SMP:

- **Topsoil** - Natural topsoil or manufactured topsoil, varies in depth with soil type but usually covering the top 20-30 cm in which plants can grow healthily;
- **Subsoil** - Layer (or horizon) of soil immediately beneath the surface topsoil. Generally less structurally developed and less nutrient rich than the topsoil;
- **Field Capacity** - The condition in which the soil is saturated with water and any water from rainfall will infiltrate quickly under the force of gravity or create waterlogging;
- **Soil Ped** - Soil peds are natural, relatively permanent aggregates of soil particles, separated from each other by voids or natural surfaces of weakness; and which persist through cycles of wetting and drying;
- **Plastic** - A plastic material can be moulded into a shape and the material will retain that shape. Where practicable, soil should not be handled when in a plastic state (considered to be too wet) and if handling is unavoidable additional measures must be in place;
- **Lower Plastic Limit** - The lower plastic limit is defined as the moisture content at which soil begins to behave as a plastic material. If the moisture content is below the lower plastic limit, it is considered to behave as a solid, or a non-plastic material;
- **Tilth** - Soil tilth is its physical condition, especially in relation to its suitability for planting or growing a crop. Soil with good tilth has large pore spaces for air infiltration and water movement. Roots only grow where the soil tilth allows for adequate levels of soil oxygen. Such soil also holds a reasonable supply of water and nutrients;
- **Soil series** - the lowest category in the soil classification system and are precisely defined based upon particle-size distribution, parent material (substrate) type, colour and mineralogical characteristics; and
- **Soil associations** are groupings of related soil series.

1.3 Roles and Responsibilities

1.3.1 The effective implementation of the Outline SMP requires that roles and responsibilities are clearly defined and understood. Specific job titles, roles and responsibilities will be defined by the Contractor in the location specific construction management plans and detailed SMP. The roles and responsibilities are expected to be similar to those described below.

1.3.2 The site staff must be competent to perform the required tasks as they have the potential to cause an environmental impact. The training and awareness are to be ensured according to the procedures and tools described in the detailed Construction Environmental Management Plan (CEMP) and are to include measures such as the provision of toolbox talks with all personnel involved in the groundworks, communicating the principles of good practice in soil management and its goals.

Project Manager

1.3.3 The Project Manager is responsible for:

- Coordinating the delivery of all elements of the Proposed Development including ensuring conformance with the CEMP and other management plans (including SMP), as well as any incident investigation required;
- Facilitating the dissemination of generic environmental requirements to the project team;
- Oversee the implementation and review of environmental procedures throughout the project;
- Monitoring the environmental performance of the project through maintaining an overview of incidents, inspections and audits; and
- Ensuring that environmental considerations form an integral part of design and implementation of the works and to include environmental reviews as part of regular project meetings.

Site Manager/ Engineer

1.3.4 The Site Manager/ Engineer, working with the Project Manager is responsible for:

- Understanding and implementing all environmental procedures as identified in the CEMP and other management plans (including SMP), and ensuring that site operations function in compliance;
- Reviewing risk assessments and method statements (RAMS) and/ or environment method statements (EMS) submitted by the Contractor prior to beginning new works activities;
- Monitoring of Contractor compliance with plans and procedures; and
- Conducting regular site inspections.

Safety, Health and Environment Manager/ Advisor

1.3.5 The SHE Manger/ Advisor is responsible for:

- Providing site inductions and toolbox talks on safety, health and environmental matters and sensitivities to the appropriate staff prior to works being undertaken;
- Assisting the Project Manager and Site Manager/ Engineer in reviewing and approving RAMS and/ or Environmental Method Statements (EMS);
- Ensuring the RAMS/ EMPs are implemented, ensuring compliance with procedures and legislation;

- Providing technical advice on the implementation of the CEMP, and other management plans, including changes to legislative requirements and best practice; and
- Undertaking regular site inspections/ walkovers to ensure construction practice is compliant with best working practices and approved RAMS/ EMS.

Site Foreman

1.3.6 Responsible to the Site Manager for:

- Implementing the site-specific construction soil management method statements to manage soil handling and storage on site to ensure the sustainable use of the soil resource. This includes undertaking field testing of soil conditions where required (as per section 4.3 and **Table 2** and **Table 3**) after undergoing training;
- Ensuring daily records of weather conditions, stoppages and soil plasticity (moisture) testing are made and kept;
- Ensuring that works are carried out safely, under correct conditions and in compliance with wider environmental requirements; and
- Ensuring that the protection of services is maintained during the soil handling works.

The Land Officer

1.3.7 The Land Officer may be supported by an Agricultural Liaison Officer (ALO) (or similar), employed by the Contractor to provide local landowners and those with land-related interests information regarding daily construction activities.

1.3.8 The Land Officer / ALO will ensure that the specifications of the Outline SMP and site-specific construction method statements/soil management plans are implemented. It is envisaged that the ALO will have sufficient soil science experience or that he/she will work in cooperation with a Technical Specialist Advisor (TSA) with soil science capability. This will ensure awareness of any potential issues arising, which may include potential reinstatement issues which will impact upon crop losses and may culminate in increased compensation claims.

1.3.9 The main duties of the Land Officer / ALO will comprise, but will not be limited to:

- Liaison between the Contractor, landowners/tenant farmers, Viking CCS Pipeline stakeholders and the Applicant;
- Assessment of the soil condition during and after the works using tactile and visual methods;
- Assessing compliance of the work on site with the Outline SMP;
- Signing off the quality of restoration to allow for the commencement of the aftercare;
- Ensuring the adequacy of the detailed aftercare programme and its annual updates (if required);
- Soil sampling and production of annual aftercare reports; and
- Signing off completion of the aftercare.

Environmental Clerk of Works

1.3.10 An Environmental or Ecological Clerk of Works (ECoW) will be appointed for the duration of the construction. The ECoW will ensure the implementation of, and compliance with, the provisions of the CEMP and other management plans (including the SMP).

1.3.11 The ECoW may be from a company who provide a general Clerk of Works who can liaise with a team of specialists in specific environmental subjects, such as soils and agriculture, where required throughout construction, or a suitably qualified individual. The ECoW is responsible for inspections/audits of the Contractor's work site to ensure compliance with environmental standards and requirements.

Technical Specialist Advisor

1.3.12 In relation to the SMP the main duties of the Technical Specialist Advisor (TSA) will comprise, but will not be limited to:

- Providing advice with respect to construction activities and their interface with respective technical areas of expertise;
- Providing training on the application of field testing of soil conditions (as per section 4.3 and **Table 2** and **Table 3**) to nominated site staff;
- Undertaking any necessary pre-construction surveys and supervising the implementation of specific mitigation measures, where required;
- Undertaking any required monitoring related to their specialism;
- Providing reports and maintaining contact with relevant stakeholders, as required; and
Providing specific advice with respect to any issues that arise.

Others

1.3.13 As stated in paragraph 1.3.12, above, the TSA will provide training to nominated site staff (including the ALO, ECoW and others such as the site foremen responsible for soil handling operations, or other nominated personnel), who will be responsible for the application of field testing of soil conditions (as per section 4.3 and **Table 2** and **Table 3**).

1.4 Limitations of use of the Outline SMP

1.4.1 The Outline SMP should be read in conjunction with Project Documents, including the Draft CEMP (*ES Volume IV Appendix 3.1, Application Document 6.4.3.1*) and other plans and protocols referred to therein. The Outline SMP does not provide safe working guidance and should be read in conjunction with the relevant detailed construction method statements and risk assessments prepared by the appointed Contractor. Attention is drawn to the responsibilities arising from the Construction (Design and Management) Regulations (CDM) 2015 (Ref. 4).

1.4.2 Persons involved in the handling of soils and overburden or similar, and in the construction or removal of mounds or tips, must comply with the Health and Safety at Work Etc. Act 1974 and its relevant statutory provisions, in particular, those aspects which relate to the construction and removal of tips, mounds and similar structures (Ref. 5). This requirement takes precedence over any suggested practice presented in this document. The user of the Outline SMP is solely responsible for all liabilities that might arise. No liabilities are accepted for any losses of any kind arising from the use of this Outline SMP.

2 Review and update of the Outline SMP

2.1.1 As discussed above, the Outline SMP is considered to be a 'live document' as changes are likely to be required to the Outline SMP throughout the construction phase of the Proposed Development for one or more of the following reasons:

- A new environmental sensitivity is identified as a consequence of changing environmental conditions, or following more detailed or additional survey work;
- Changes are introduced into the detailed design of the Proposed Development; and/or
- Changes are introduced to construction methodology or programming.

2.1.2 The Outline SMP will be reviewed prior to commencement of construction to consider additional site-specific soils data compiled via the pre-commencement soil surveys.

2.1.3 The changes to the Outline SMP should be implemented via an agreed procedures and changes approved by the Site Manager and Land Officer or ALO.

3 Soil Resources

3.1 Overview

- 3.1.1 From purchased NATMAP Vector data, eleven soil associations have been identified within the DCO Site Boundary along with discrete areas of unsurveyed land which were classified as being urban or industrial in nature, and waterbodies.
- 3.1.2 The susceptibility of soil resources to damage when being handled is a function of soil type and is related to soil texture and structural development, along with local climatic factors. Consequently, some soils are more sensitive to damage when handled during construction than others. As described in Institute of Environmental Management and Assessment (IEMA) guidance (Ref. 6) soils of high clay content in wetter climate regions are considered to be most sensitive to damage. For example, the incorrect handling/reinstatement of a heavy (clay rich) soil whilst in a plastic state may result in a reinstated soil profile with reduced natural drainage compared to the natural soil profile and a subsequent increased risk of soil loss (erosion) due to surface water run-off. Soils with high sand fraction are considered to be less sensitive as the permeable nature of light sandy soils means that the natural structural recovery and drainage potential of these soils is more easily maintained. However, it is also noted that very light soils can be at higher risk of erosion when stockpiled and this also needs to be considered. Erodibility (erosion risk) is described in Cranfield University's evidence-based report (Ref. 7).
- 3.1.3 The soil associations in the DCO Site Boundary are described in **Table 1**. The geographic distribution of soil associations is presented in **Figure 10-3** of the *ES Volume III (Application Document 6.2)*, and **Figure 1** (below) shows the spatial extent of soil sensitivity to damage when being handled.

Figure 1: Spatial Extent of Soil Sensitivity

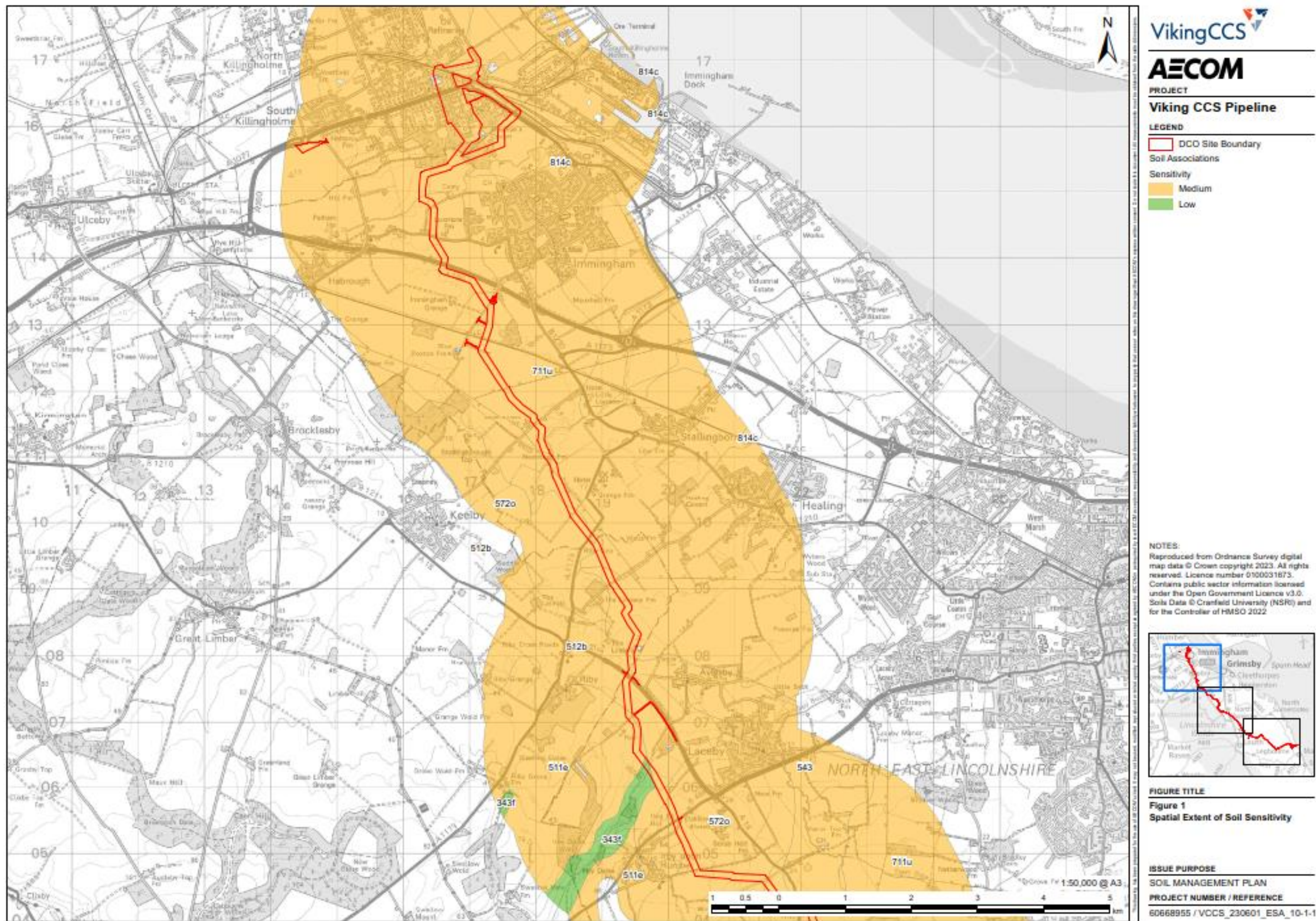

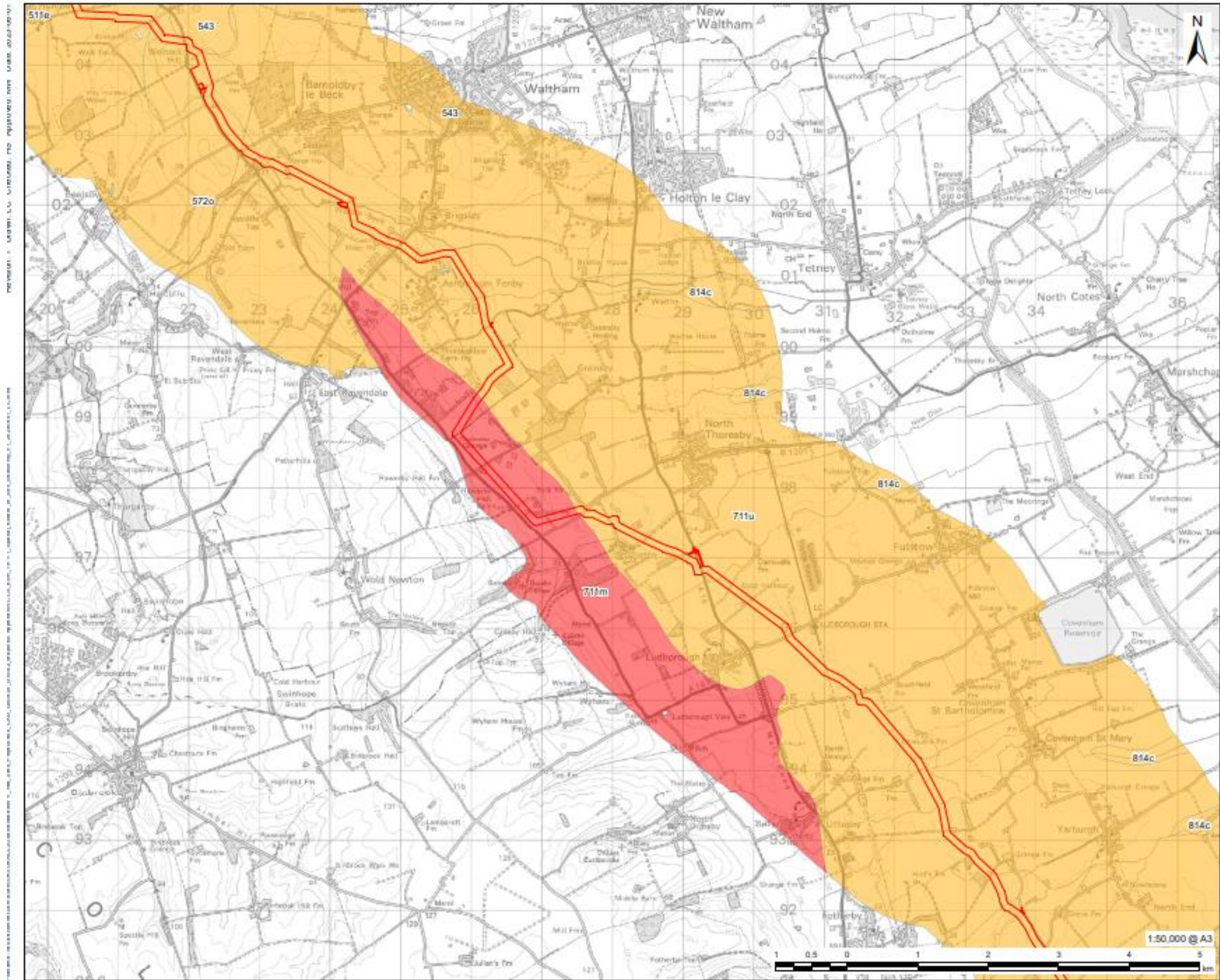

Viking CCS
AECOM

PROJECT
Viking CCS Pipeline

LEGEND

- DCO Site Boundary
- Soil Associations
- Sensitivity
 - High
 - Medium

NOTES:
Reproduced from Ordnance Survey digital map data © Crown copyright 2023. All rights reserved. Licence number 0100031673. Contains public sector information licensed under the Open Government Licence v3.0. Soils Data © Cranfield University (NSR) and for the Controller of HMSO 2022

FIGURE TITLE
Figure 1
Spatial Extent of Soil Sensitivity

ISSUE PURPOSE
SOIL MANAGEMENT PLAN
PROJECT NUMBER / REFERENCE
60668955 / VCCS_230601_ESA_10-1-1

Revision: 1 Drawn: LC Checked: HS Approved: MW Date: 2023-06-01
Project No: 60668955 / VCCS_230601_ESA_10-1-1

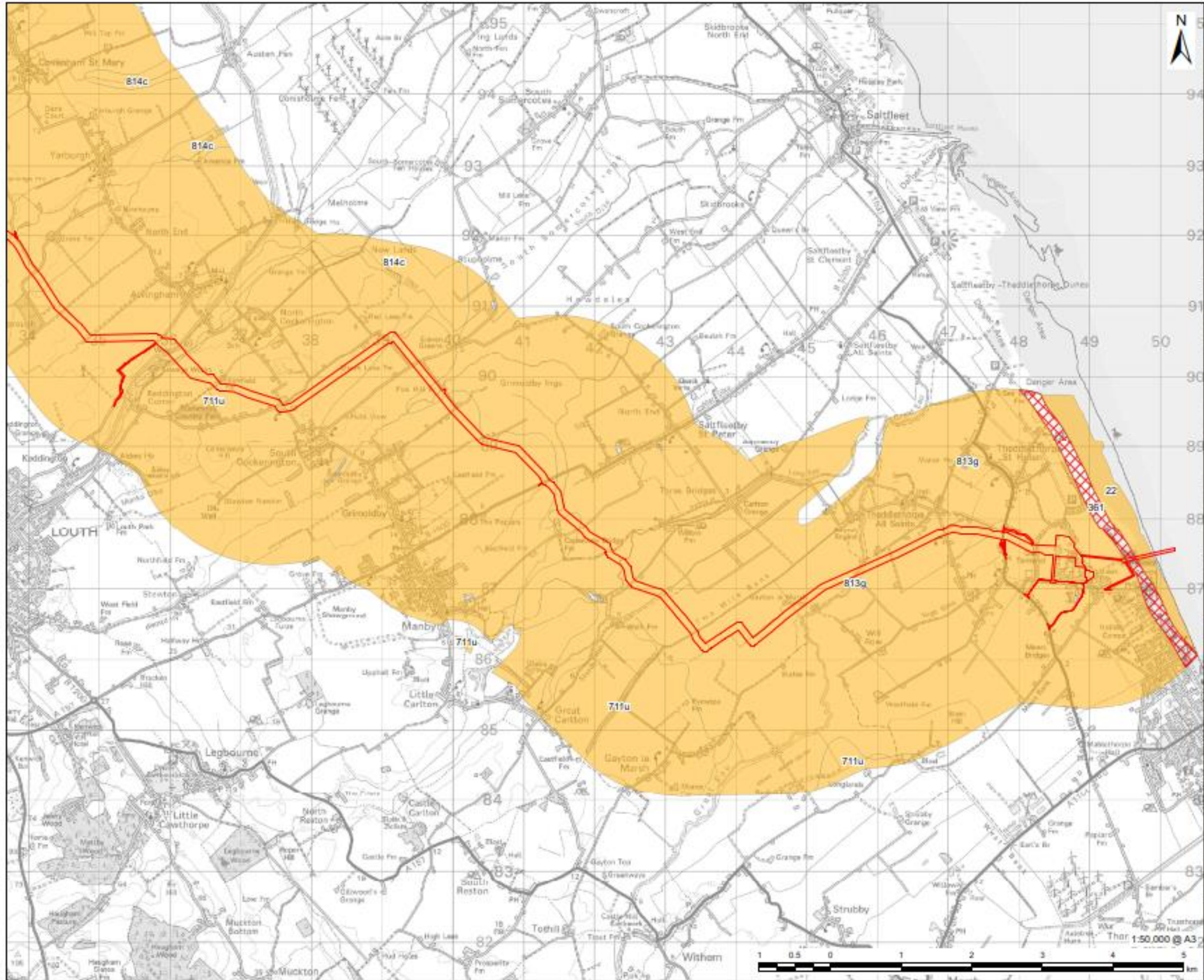

PROJECT
Viking CCS Pipeline

LEGEND

	DCO Site Boundary
	Soil Associations
	Sensitivity
	Medium
	Erodability
	High Risk (Wind)

NOTES:
Reproduced from Ordnance Survey digital map data © Crown copyright 2023. All rights reserved. Licence number 0100031673. Contains public sector information licensed under the Open Government Licence v3.0. Soils Data © Cranfield University (NSRI) and for the Controller of HMSO 2022



FIGURE TITLE
Figure 1
Spatial Extent of Soil Sensitivity

ISSUE PURPOSE
SOIL MANAGEMENT PLAN
PROJECT NUMBER / REFERENCE
60668955 / VCCS_230601_ESA_10-1-1

3.2 Soils at Low Risk of Damage

- 3.2.1 The Newmarket 1 and Saline 1 associations, which are located to the south of Section 2 and the south of Section 5 respectively, are classed by the IEMA guidance (Ref. 6) as being of low sensitivity / low risk of damage due to their sandy texture, drainage characteristics and FCD. It is also noted that these soils are at small and very small risk of erosion (Ref. 7). Collectively these soils comprise 2.63 ha or 0.4% of land within the DCO Site Boundary.
- 3.2.2 Good practice measures for the sustainable management of soil resources following those recommended in Defra's Construction Code of Practice for the Sustainable Use of Soils on Construction Sites (Ref. 1); MAFF's Good Practice Guide for Handling Soils (Ref. 2) and its update the IoQ's Good Practice Guide for Handling Soils in Mineral Workings (Ref. 3), will provide appropriate protection to these soils as they are generally more resistant to damage and loss.

3.3 Soils at Medium Risk of Damage

- 3.3.1 The majority of soils within the DCO Site Boundary are classed as being of medium sensitivity / medium risk of damage during handling (Ref. 6) as shown on **Table 1**. These soil associations are loamy and clayey soils that do not fall into Wetness Classes V or IV even when undrained and make up 619.43 ha or 95% of land within the DCO Site Boundary. These soils are all at small and very small risk of erosion (Ref. 7).
- 3.3.2 Good practice measures for the sustainable management of soil resources will mostly provide appropriate protection to these soils, however damage is likely to occur if worked in less-than-ideal conditions, for example when the soils are wet. Therefore, on a location-by-location basis, depending upon factors such as physical soil properties, local topography, and the time of year / climatic conditions when the soils are being worked, bespoke mitigation measures may be required, such as specific methods for wet working. The soils should be given appropriate consideration because of their importance for agricultural production.

3.4 Soils at High Risk of Damage or High Risk of Erosion

- 3.4.1 The Salop association comprises loamy clayey soils which are classed as Wetness Class IV when undrained. As the drainage status of the land within the DCO Site Boundary cannot be confirmed at this time, a Wetness Class of IV has been assumed as a worst case resulting in these soils being classed as being of high sensitivity / high risk of damage according to IEMA guidance (Ref. 6). This association comprises 29.31 ha or 4.5 % of land within the DCO Site Boundary and occurs in Section 3 to the east of the A18 and East Ravendale and Wold Newton.
- 3.4.2 Development on these soils should be avoided if possible, however where this is not possible, they require special consideration and careful planning of construction methods, i.e. bespoke mitigation measures, in order to preserve their structure and function. For the Salop association this means that these clayey soils which are prone to waterlogging are only handled when appropriately dry or that specific methods for wet working are in place.
- 3.4.3 Additionally, the Sandwich association, which is a very sandy soil often supporting sand dunes habitats is identified as being at high risk of wind erosion and therefore is also categorised as high risk of damage (loss) during handling and stockpiling. This association comprises 0.55 ha 0.08% of land within the DCO Site Boundary and occurs to the south of Section 5. Through mitigation by design (embedded mitigation), it is anticipated that impacts to these soils will be avoided as they occur over the existing Lincolnshire Offshore Gas Gathering System (LOGGS) 36" pipeline and therefore there will be no construction

activities required. It is also noted that these soils coincide with the designated habitats of the Saltfleetby - Theddlethorpe Dunes Special Area of Conservation (SAC) National Nature Reserve (NNR) and Site of Special Scientific Interest (SSSI), and the Humber Estuary Special Protection Area (SPA) and Ramsar site. In the unlikely event that these soils are to be handled the detailed AMP should include measures such as described below.

- 3.4.4 The stockpiles for these erosion prone soils should be formed and seeded as described in sections below. The stockpile may then be covered in with an appropriate geotextile to stabilise it until the vegetation cover becomes effective. Depending upon specific site and soil conditions, other bespoke mitigation measures for erosion sensitive soils will be expected to include, but not necessarily be limited to, the use of specialist surface run-off control systems and wind barriers.
- 3.4.5 For soil storage, geotextiles that are permeable and biodegradable are recommended. This will prevent soil movement but allow for water and air to pass through maintaining soil in a good condition. A geotextile that is able to support plant rooting will be beneficial and able to aid stockpile stability and reduce erodibility. Details on the excavation of stockpiles with geotextile are given further in the SMP.

Table 1: Soil Associations in the DCO Site Boundary

Soil Association	General Description (<i>taken from Ref. 8</i>)	Area (ha) (and % of Section)	Sensitivity*	Erodibility**
Newchurch 2 (814c)	Loamy and clayey soils of coastal flats with naturally high groundwater developed over stoneless clayey marine alluvium. Where control is effective soils are only occasionally waterlogged in winter (Wetness Class II) but elsewhere they are seasonally waterlogged (Wetness Class III)	25.90 (3.97 %)	Medium	Very small risk (water)
Holderness (711u)	Mainly slowly permeable fine loamy and moderately permeable coarse loamy soils on chalky till and glaciofluvial drift. Also includes narrow strips of clayey alluvial soils. Slowly permeable and seasonally waterlogged or occasionally waterlogged (Wetness Class III to II).	415.89 (63.79 %)	Medium	Small risk (water)
Burlingham 2 (572o)	Deep fine loamy soils with slowly permeable subsoils and slight seasonal waterlogging (Wetness Classes II or III). . Some slowly permeable seasonally waterlogged fine loamy soils. Some well drained	46.05 (7.06 %)	Medium	Small risk (water)

Soil Association	General Description (<i>taken from Ref. 8</i>)	Area (ha) (and % of Section)	Sensitivity*	Erodibility**
	fine and coarse loamy soils. Developed over chalky till.			
Landbeach (512b)	Permeable calcareous coarse loamy soils affected by groundwater over glaciofluvial sand and chalky gravel. Some deep, in part non-calcareous fine and coarse loamy soils affected by groundwater. The soils are permeable and either well drained or only occasionally waterlogged (Wetness Classes I or II).	13.95 (2.14 %)	Medium	Very small risk (water)
Swaffham Prior (511e)	Well drained calcareous coarse and fine loamy soils over chalk rubble. Some similar shallow soils. Deep non-calcareous loamy soils in places. (Wetness Class I) Striped and polygonal soil patterns locally. Slight risk of water erosion.	7.79 (1.19 %)	Medium	Small risk (water)
Newmarket 1 (343f)	Shallow well drained calcareous sandy and coarse loamy soils over chalk or chalk rubble. Some similar deeper sandy soils, often in an intricate striped pattern. Well-drained (Wetness Class I).	1.69 (0.26 %)	Low	Small risk (wind)
Arrow (543)	Developed in glaciofluvial and river terrace deposits, this association is composed predominantly of coarse loamy soils. Because of the variable nature of the underlying drift and differences in soil water regime, local variation in component soil series occurs. The soils are permeable but are seasonally waterlogged on undrained land (Wetness Class II and III), but mostly respond well to drainage measures after which they are usually well drained (Wetness Class I).	1.27 (0.19 %)	Medium	Small risk (water)

Soil Association	General Description (<i>taken from Ref. 8</i>)	Area (ha) (and % of Section)	Sensitivity*	Erodibility**
Salop (711m)	Slowly permeable seasonally waterlogged reddish fine loamy over clayey, fine loamy and clayey soils associated with fine loamy over clayey soils with slowly permeable subsoils and slight seasonal waterlogging. Most of the soils when undrained are waterlogged for long periods in winter (Wetness Class IV). Surface waterlogging results from the combination of slowly permeable subsoil and slow surface run-off from relatively flat land. The soils can be improved to Wetness Class III with underdrainage.	29.31 (4.50 %)	High	Very small risk (water)
Wallasea 2 (813g)	Deep stoneless clayey soils developed over reclaimed marine alluvium. Calcareous in places. Some deep calcareous silty soils. (Wetness Class I to II).	107.69 (16.52 %)	Medium	Very small risk (water)
Sandwich (361)	Mainly deep well drained calcareous and non-calcareous sandy soils supporting sand dune and some wetland habitats. Very limited agriculture and coniferous woodland use as the soils are droughty, and unstable when ploughed. Some sparsely vegetated unstable soils. Waterlogged soils in hollows locally. Shingle bars and spits locally extensive.	0.55 (0.08 %)	Low	High risk (wind)
Saline 1 (0220)	Soils of variable texture flooded by high tides developed over marine alluvium. Many are soft and unripened, others, often on higher sites or of sandy texture, are firm and ripened. Frequently calcareous.	0.94 (0.14 %)	Low	Very small risk (water)

Soil Association	General Description (<i>taken from Ref. 8</i>)	Area (ha) (and % of Section)	Sensitivity*	Erodibility**
Waterbodies (no soil cover)		0.89 (0.14 %)		
TOTAL		651.92 (100 %)		
<p>*As set out in the IEMA guidance (Ref. 6) the sensitivity of the soil resource is based upon its texture and drainage characteristics (Ref. 8) and the FCD (Ref. 9).</p>				
<p>** Risk of erosion by wind or water, as set out in Ref. 7.</p>				

4 Good Practice Mitigation

4.1 General principles of soil handling

4.1.1 The main threats to soil resources at construction sites are trafficking of vehicles/plant and incorrect handling, which can cause damage to soil structure through compaction and smearing (both effects are sometimes referred to as deformation). These effects compromise the ability of the soil to perform its functions, such as providing adequate amounts of water, air and nutrients to plant roots. The risk of compaction and smearing increases with soil wetness.

4.1.2 To minimise the risk of damage to soil structure, the following main rules should be observed during all soil handling tasks:

- No driving of vehicles/plant or materials storage to occur outside designated areas;
- No driving of vehicles/plant on reinstated soil (topsoil or subsoil) other than for the purposes of reinstatement, including cultivation or seeding;
- Only direct movement of soil from donor to receptor areas (no triple handling and/or ad hoc storage);
- No soil handling to be carried out when the soil moisture content is above the lower plastic limit (the soil is plastic, see Soil Condition for an infield test and **Table 2** and **Table 3**);
- Soils should only be moved under the driest practicable conditions and this must take account of prevailing weather conditions. (see rainfall “stop” criteria in Stop Conditions);
- No mixing of topsoil with subsoil, or of soil with other materials;
- Soil only to be stored in designated soil storage areas;
- Plant and machinery only work when ground or soil surface conditions enable their maximum operating efficiency;
- All plant and machinery must always be maintained in a safe and efficient working condition; and
- Daily records of operations undertaken, and site and soil conditions should be maintained (see section 7 for the summary of monitoring and record keeping schedule).

4.1.3 Low ground pressure (LGP models) and tracked vehicles should be used where possible. This will greatly minimise the extent and/or intensity of the soil loosening required after restoration. Consequently, it will reduce the costs and potential delays due to the need for additional soil cultivation.

4.1.4 The location-specific methods statements (or similar) must be defined based on the results of detailed site-specific soil survey which have been or will be conducted on all land which will be subject to direct disturbance due to the Proposed Development (see Section 1). The survey results should be used to specify in detail:

- The ‘before’ statement of physical characteristic of the soil to be disturbed;
- Where bespoke mitigation measures are required, and what these bespoke measures entail;
- The depth and properties of topsoil; and

- The depth of subsoil and presence of any distinct soil horizons.

4.2 Stop Conditions

Adverse Weather

- 4.2.1 In certain weather conditions, the handling of topsoil and subsoil must be effectively managed to prevent damage. Topsoil and subsoil handling may need to be ceased under the following criteria:
- In drizzle and/or intermittent light rain, handling can continue for up to four hours unless the soils are already in a plastic state (see Soil Condition);
 - If there is heavy rain (e.g. heavy showers, slow moving depressions), handling must stop immediately;
 - If there is sustained heavy rainfall of more than 10mm in 24 hours, soil handling must be suspended and not restarted until the ground has had at least a full day to dry, or an agreed soil moisture limit can be met; and
 - Soil shall not be handled or trafficked over/driven on immediately after a heavy rainfall (or snow/hail) in a waterlogged condition, or when there are standing pools of water on the soil surface.
- 4.2.2 If the works are interrupted by a rainfall event, soil stripping should be suspended; and where the soil profile has already been disturbed, the works should be completed to the base level in that location.
- 4.2.3 Before recommencing work, soil moisture content must be tested, as described below in Soil Condition and **Table 2** and **Table 3** and only recommence if soil moisture is below the lower plastic limit. The weather forecast must also be checked and works only recommenced if agreed by the ALO.
- 4.2.4 Additionally, soil should not be handled or trafficked over/driven on when the ground is frozen or covered by snow.
- 4.2.5 The above criteria should be clearly understood by all personnel.

Soil Conditions

- 4.2.6 Irrespective of the weather, soils should not be handled when in a plastic state (when moisture content exceeds their lower plastic limit); and as a general rule should be dry when handled. This section and **Table 2** and **Table 3** set out the methodology for determining whether soils are in a state where they can be handled.
- 4.2.7 A project-wide seasonal constraint to the construction programme is not recommended as this may not be achievable in practice. The soil types identified within the DCO Site Boundary combined with winter rainfall in the Region, mean that soil handling should be restricted to the drier periods of the year when the soils are below their plastic limit wherever possible. However, due to the scale of the Proposed Development, it is understood that some soil handling when the soils are wet (in a plastic state) may be necessary, **although wet handling of soils should only be undertaken if extenuating circumstances arise and there is no practicable alternative. Examples of extenuating circumstances include:**
- A requirement to complete a rail crossing within a fixed window of time as agreed with Network Rail;
 - A requirement to complete a watercourse crossing within a fixed window of time as agreed with the Environment Agency, Drainage Board, or other authority;

- A requirement to complete works within a specified area within an agreed window of time to mitigate disturbance to protected species or habitats; or
- Where, due to factors such as soil type, geology or topography, ground conditions within a specified area are such that the soils are waterlogged / in a plastic state even after a prolonged period of dry weather and are not expected to attain a dry state.
- Emergency works during construction or if there is a public health or safety risk.

4.2.8 Extenuating circumstances would therefore apply to discrete areas and would be of a small scale compared to the normal dry working practices.

4.2.9 Additionally, these wet working measures should be applied to the highly sensitive (wetter, clay) soils of the Salop association, as required.

4.2.10 If the soil is excavated and placed in stockpiles when wet (above the plastic limit), they are easily compacted by the machinery handling them, or by the weight of the soil above in the stockpile, and additional measures will be required to minimise damage to soil structure as far as practicable. Such additional measures may include, but are not limited to, reducing stockpile heights to low single tiered mounds, reducing the number of times the soil is handled during wet, using equipment that is less detrimental to soil structure (excavator and dump truck). As well as this damage to soil structure, when soils within a stockpile are compacted, the core of the stockpile remains anaerobic throughout the storage period. This damage results in the soil being very difficult to handle and re-spread at the time of reinstatement (i.e., it will not be in a friable state and will not break down into a suitable tilth). In this case, in order to achieve the required standard of restoration, a period of drying and appropriate additional cultivation is required (to repair soil structure and re-aerate the soil) to ensure the soil is acceptable for planting. Should wet handling of soils be required, appropriate soil handling, drying and cultivation methodologies will be set out in the Detailed SMP and in site-specific construction method statements, as required. Wet working of soils will be monitored by a suitably qualified individual; and toolbox talks will be given to site staff prior to any wet working commencing to ensure that the specific requirements are fully understood.

4.2.11 For arable land, the period where the soil conditions will generally be the driest, and most optimum for soil handling operations, typically occur in the summer following the spring crop harvest, when the plant evapotranspiration will have dried the soil. However, this does not exclude soil handling at other times of the year.

4.2.12 Once the placement of soils into each stockpile has been completed, rainfall and soil moisture conditions are of lesser importance, providing they do not lead to significant environmental impacts, such as erosion and discharges of sediment laden water from the stockpiles to drainage ditches and other watercourses.

4.3 Field testing of soil conditions

4.3.1 Prior to the start or recommencement of soil handling operations, the following two stage methodology, comprising a moisture state test and a consistency test should be undertaken by a suitably trained person (see section 1.3), noting that if the trained person is unsure whether conditions are suitable, no work is to be undertaken until advice had been sought from the TSA. This two staged approach to the field testing of soil conditions is set out in Table 4.2 of the IoQ guidance (Ref. 3) and is considered to be less open to interpretation and easier to conduct than use of consistency testing (**Table 3**) alone.

4.3.2 At least five points per area to be worked on a given day should be sampled (a minimum of one point per 50 m of the length of the working area, or two samples per hectare). The sample should be a composite of at least five subsamples from around each sample point. Samples of both topsoil and subsoil should be taken and sampled separately.

Soil moisture state

4.3.3 The samples should first be tested for soil moisture state as per the methodology in **Table 2**.

Table 2: Testing for Soil Moisture State

Test	Handling allowed?
If soil sample is wet, films of water are visible on the surfaces of soil particles and aggregates; or If soil sample readily deforms into a cohesive 'ball' when squeezed	Soils should not be handled, or if handling cannot be avoided due to extenuating circumstances, additional measures will be required as per Soil Conditions section above.
Soil peds break up/crumble readily when squeezed in the hand. Sample does not form a cohesive ball.	Soils can be handled.
If the sample is moist, there is a slight dampness when squeezed between the fingers, but it does not significantly change colour (darken) on further wetting.	No handling by dozers but may be handled by excavators if the consistency test is passed.
Sample is dry and brittle. Sample looks dry and changes colour (darkens) on wetting.	Soils can be handled if the consistency test is passed.

4.3.4 Where required as per **Table 2**, samples should be further tested for consistency as per the methodology in **Table 3**.

Table 3: Testing for Soil Consistency

STEP A	
Attempt to roll sample into a ball by hand	
It is impossible because the soil is too hard (dry).	Soils can be handled.
It is impossible because the soil is too loose (dry).	Soils can be handled.
It is impossible because the soil is too loose (wet).	Soils should not be handled (or if handling cannot be avoided (exceptional circumstances arise) additional measures be required as per Soil Conditions section above).
It is possible to roll the sample into a ball by hand.	See Step B
STEP B	
Attempt to roll the ball into a thread of 3 mm diameter on a flat non-adhesive surface using light pressure from the flat of a hand	
It is impossible as the soil crumbles or disintegrates.	Soils can be handled.
It is possible to roll a 3 mm diameter thread.	Soils should not be handled (or if handling cannot be avoided (exceptional circumstances arise) additional measures be required as per Soil Conditions section above).

- 4.3.5 The final decision on whether soil handling can commence will be made by the ALO and be based upon at least 80% of samples passing the particular test.
- 4.3.6 The above criteria should be clearly understood by all personnel.

4.4 Soil Preparation

- 4.4.1 Mark and signpost the undisturbed areas where no construction activities or vehicle trafficking over/driving on is to take place per detailed works plans and construction method statements (to be prepared post-consent by the Contractor). Any trees, hedgerows or valuable habitats which are to be retained should be marked out with barrier tape; and subsequently protected and managed.
- 4.4.2 As per the requirements of detailed works plans and construction method statements (to be prepared post-consent by the Contractor), any underground services crossing the area of soil stripping are to be surveyed and their depth and position clearly marked to ensure they are not impacted by the stripping works. After stripping, to ensure the integrity of the service infrastructure is maintained, the service location may require fencing off; or if the area over the service is to be trafficked additional protection or mitigation may be required.
- 4.4.3 Mark each soil storage area for different types of topsoil, subsoil and mineral substrate. In some locations, the excavated soil profile may contain more than one distinct subsoil horizon (layer). Where this occurs, due to the different properties of the different horizons, they must be excavated and stored separately. Locations requiring the storage of more than one subsoil horizon should be identified through review of the soil survey records and specified in the location-specific construction method statements.

- 4.4.4 At designated crossings (specified in the location-specific construction method statements) a 2 m width of topsoil will be left unstripped at either side of the ditch/watercourse to act as a filter for water run-off.
- 4.4.5 To reduce the likelihood of anaerobic conditions developing within the topsoil stockpile, prior to the soil strip commencing the topsoil surface should either be bare, under stubble, or have only short surface vegetation. To achieve short surface vegetation (for example in areas of permanent pasture or grassland), if not already done so prior to the land being handed over to the Proposed Development, the area should be mown or strimmed. Cuttings should be lifted and disposed of off-site to a suitably licenced facility with reuse and recycling favoured over disposal (e.g., recycling via a local composting facility). Cuttings must not be added to or mixed with the stripped soil, as the presence of excessive amounts of plant material in the stockpile will be detrimental to its quality due to its putrefaction (rotting) in anaerobic conditions. Alternatively, the vegetation may be killed off by application of a suitable, Environment Agency approved, non-residual herbicide applied not less than two weeks prior to commencement of soil stripping operations at the location. Herbicide may only be used with the consent of the landowner and subject to the conditions/restrictions within the contract.

4.5 Soil Stripping

- 4.5.1 Soil horizons should be stripped according to their natural occurrence and separately according to their main functional characteristics. Therefore, to avoid mixing of different soil horizons and soil types, topsoil and subsoil will be handled and stored separately, this includes the separate handling and storage of any different district subsoil horizons; and similarly different type of topsoil and subsoil will also be handled and stored separately. See also section 4.9: Stockpile Records. Topsoil can be stored on either topsoil (of the same type) or on subsoil. Subsoil can ONLY be stored on subsoil and therefore the topsoil must be stripped from subsoil storage areas in advance of subsoil stripping and subsequent storage.
- 4.5.2 The stripping method should follow one of the suggested methods as described in the Institute of Quarrying's Good Practice Guide for Handling Soils in Mineral Workings (Ref. 3). As stated above, topsoils and subsoils will be stored separately. Prior to stripping commencing, the location of each stockpile should be determined, ensuring separation of the different soil types to be stripped.
- 4.5.3 It is expected that (in most locations) the excavated soil will be stored on the margin of the working area and that the use of dumper trucks will not be required. Where soils are to be stored away from the excavation area, two excavators and one transport vehicle will be required for soil stripping operations. One excavator will be required to undertake the soil stripping and the other to form the soil stockpiles. The excavator undertaking the soil stripping should be fitted with a toothed bucket, except where use of a toothless bucket is required to prevent damage to potential underlying archaeology. The method, if correctly carried out, should avoid severe compaction as soil trafficking is minimised. The concept of this method is shown in **Plate 1** and **Plate 2**.
- 4.5.4 The size of the earthmoving plant to be used should be tailored to the size of the area to be stripped and the space available within the working area. The use of a long reach excavator, which will minimise the need for movement across the soil surface, and the use of tracked vehicles or vehicles with a low ground bearing pressure is recommended to further reduce soil compaction.
- 4.5.5 Prior to commencement of soil stripping, the width of each strip must be determined. Strip width is determined by the length of the excavator boom less the stand-off to operate; typically, three to four metres. The strip width should make full use of the reach of the

excavator. This will maximise the time the excavator can remain at a fixed location, before moving further along the strip; minimising the number of locations subject to the weight of standing plant.

- 4.5.6 Where the stripping operation is likely to be interrupted by rain, or there is likely to be overnight rain, remove any exposed subsoil down to the basal layer before suspending operations. Make provisions to protect base of current or next strip from ponding/runoff by sumps and grips, and also clean and level the basal layer. At the start of each day ensure there is no ponding in the current strip or operating areas, and the basal layer is to level with no ruts.

4.6 Soil Stripping for Archaeological Works

- 4.6.1 The Applicant has engaged a suitably experienced archaeologist(s) to prepare an Archaeological Mitigation Strategy to fully describe the archaeological mitigation measures to be implemented in relation to the Proposed Development. These works, including Detailed Archaeological Excavation works, are currently programmed for late summer / autumn 2023 and therefore will be completed in advance of main construction activities (see Chapter 8: Historic Environment (*Application Document 6.2.8*)).

- 4.6.2 Where archaeological investigations require the handling of soils, the soils will be stripped as per agreed in the Archaeological Mitigation Strategy (under archaeological supervision where required) to a depth where archaeological deposits are exposed. The soil strip will be subject to the mitigation measures set out in this document with respect to the management and protection of soil resources; however, a toothless bucket may be employed to prevent damage to the underlying archaeology. It is expected that (in most locations) the excavated soil will be stored on the margin of the working area and that the use of dumper trucks will not be required.

Plate 1: Stripping with excavators and dump trucks: removal of topsoil from a strip. Reproduced from Part 2: Sheet A of IoQ (2021) (Ref. 3).

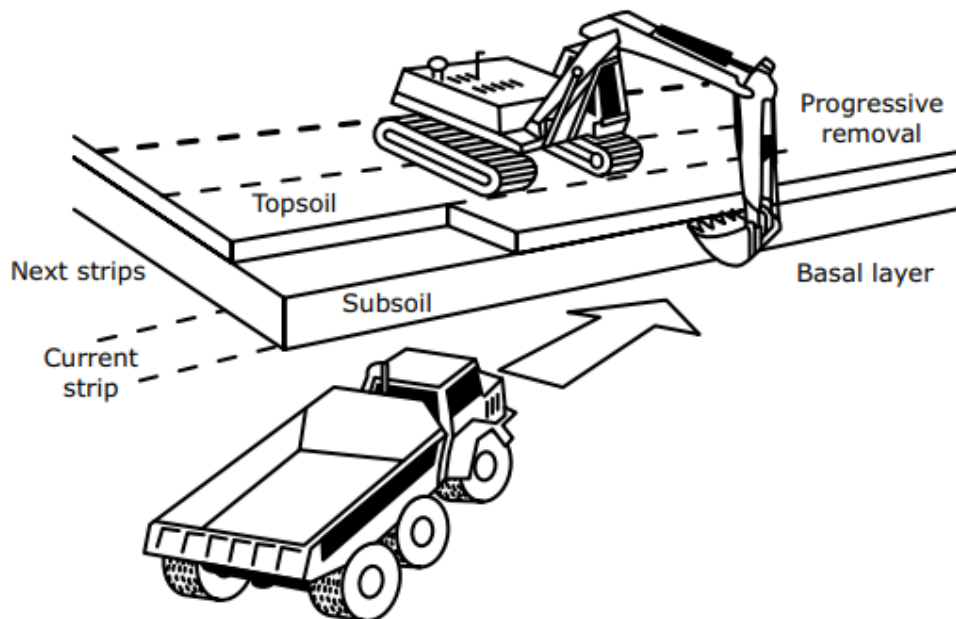
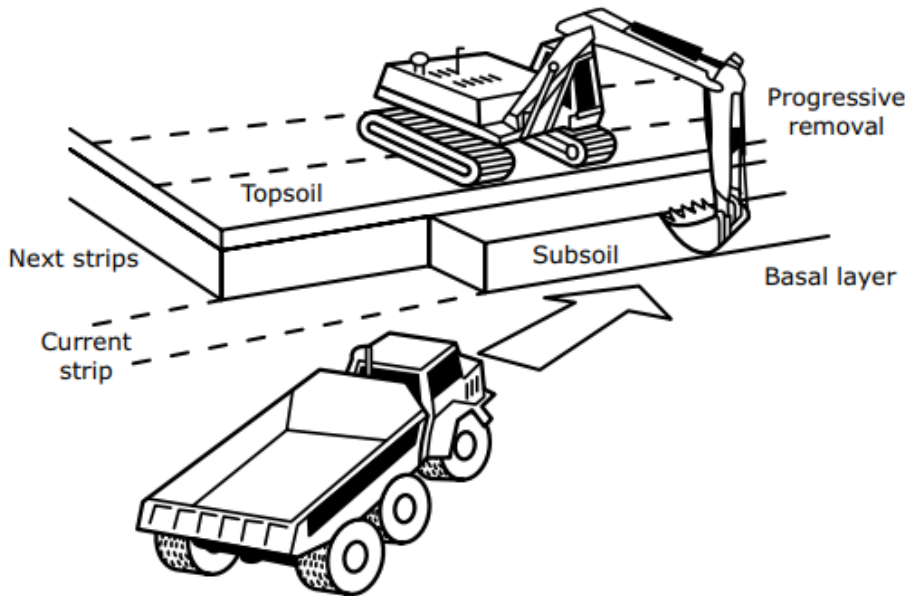

Plate 2: Stripping with excavators and dump trucks: removal of subsoil from a strip. Reproduced from Part 2: Sheet A of IoQ (2021) (Ref. 3).



- 4.6.3 The depth of the topsoil strip is to be determined on a 'location by location' basis using the soil survey data. During the strip, the excavator should stand on the surface of the topsoil, digging the topsoil to the required depth and forming the stockpile or loading it into the transport vehicle (dump truck). Following topsoil removal, the subsoil can be excavated (if required). Topsoil should be recovered to the full width of the strip without contamination with the subsoil. The boundary between the topsoil and subsoil is usually clearly visible through a change in colour (the topsoil being much darker due to greater organic matter content). However, this may not always be the case, as often the topsoil gradually transitions into subsoil, and their colours are similar. Therefore, the depth of the topsoil to be stripped must be determined by measuring the depth from the surface (excluding any vegetation) using the detailed soil survey data as described above.
- 4.6.4 The key points to minimise soil compaction and maximise its readiness for reuse are:
- The operations of the vehicles (excavators and dumper trucks, if relevant) on the topsoil should be minimised;
 - Plant and machinery are to only work when ground conditions enable their maximum efficiency;
 - Soils should typically only be handled when dry (i.e., when tests set out in **Table 2** and **Table 3** are passed);
 - Stop conditions must be observed;
 - Protect the subsoil from ponding of water by diverting water inflow away from it; and
 - Do not work when there is standing water on the topsoil or subsoil surface.

4.7 Stockpiles

Creation of Stockpiles

- 4.7.1 Correct storage/stockpiling will maintain soil quality and minimise damage to soil structure and soil biota. This ensures that the soil will readily recover once re-spread, promoting timely and effective restoration. Stockpiled soil must not be vulnerable to compaction or erosion;

must not cause pollution to surrounding watercourses; and must not increase flood risk to the surrounding area.

- 4.7.2 Potential soil erosion and water pollution can be minimised through a number of good practice measures, including, but not limited to; the avoidance of trafficking over/driving on the soil stockpiles, the seeding of stockpiles; and the use of intermittent spaces in the stockpiles.
- 4.7.3 To accommodate the mitigation described in *ES Volume II: Chapter 11: Water Environment (Application Document 6.2.11)*, topsoil and subsoil will not be stored directly adjacent to the watercourse but will be stored a minimum of 20m from the watercourse, with additional mitigation such as silt fences installed if there is a risk of sediment entering the watercourse. No topsoil or subsoil will be stored within a fluvial or surface water flood zone (flood zone 2 and 3) unless supported by a risk assessment (i.e. consideration of weather forecast and duration of storage) and additional mitigation (i.e. drainage bypass channel for overland flow). Where site constraints mean that it is not possible to maintain a 20m buffer from a water body, additional mitigation measures will be implemented to provide an adequate barrier between the potential source of contaminated runoff and the receptor. Smaller stockpiles could be created, reducing the pile height. Gaps shall be left where necessary to allow for surface water drainage and avoid the catchment (ponding) of water behind stockpiles. If storing soils near to hedges or hedgerows that require maintenance, the Land officer or ALO should be consulted on a sufficient track width for agricultural machinery and vehicles to undertake the maintenance, e.g. hedge cutting. Soil should not be stored in the root protection area of trees.
- 4.7.4 Ecologically important soils, for example woodland or hedgerow soils, must be stripped and stored separately to ensure the seedbank is retained and not mixed with neighbouring agricultural soils. These stockpiles must be appropriately marked out and clearly signed to ensure that they are easily identifiable at restoration, as specified in the location-specific construction method statements.
- 4.7.5 Generally, topsoil stockpiles should not exceed 3 m in height and subsoil stockpiles should not exceed 5 m in height. However, if the soil to be stockpiled is dry (below the plastic limit) formation of higher stockpiles may be permissible, if required, as the soil is likely to remain dry in the core of the stockpile for the entire storage period. However, the appropriateness of higher stockpiles will need to be established on a location-by-location basis.
- 4.7.6 Stockpiles are to be formed by 'loose-tipping' followed by 'shaping' to form a level surface on top of the pile and uniform gradients down the sides. During 'forming', the top and sides should be smoothed so that they can shed water, ensuring that the entry of the water to the stockpile is limited and that the stored soil remains dry; and helping prevent erosion and ponding. This is achieved by dragging the bottom of the excavator bucket along the stockpile surface.
- 4.7.7 The natural angle of repose of a soil, and hence the maximum gradient (slope) of the stockpile sides, depends upon its texture and moisture content. The maximum achievable slope angle is 40° however, shallower angles are often more appropriate. Where soil bunds are likely to be in situ for a long period (usually greater than six months), they should be seeded and maintained. In this case, a maximum slope of 25° (1 in 2) is considered appropriate, as it would allow safe working conditions during stockpile maintenance (e.g., strimming), however this will be defined in location-specific construction method statements. Where soil bunds are to be in situ temporarily or short term, usually less than six months, they may not require seeding. However, weather conditions and soil sensitivity to erosion should be considered, and appropriate measures put in place to reduce soil erosion where necessary.

- 4.7.8 The topsoil and subsoil stockpiles along pipeline trenches are to be formed using one backacting/ 360° excavator as they will be too close to the excavation to require transport in a separate vehicle.
- 4.7.9 If transport is required, follow the method described in the IoQ Guide, Part 2 Sheet B: Building Soil Storage Mounds with Excavators and Dump Trucks illustrated in **Plate 3** (Ref. 3). A dump truck should transfer soil material between the stripping and storage areas. The dump truck should enter the storage area, reverse and back-tip the soil load starting at the furthest end of the stockpile (see **Plate 3**). Repeat the process of tipping the soil against the forming stockpile and without the wheels traversing onto previously tipped material. For this operation, a second back-acting/ 360° excavator will be required with the boom reach allowing it to form a stock pile of up to 4 m while standing on it. Use of a front-loading machine to form the stockpile is possible if this is a Contractor's preference. If this alternative is chosen; the tipped soil must not be travelled or pushed with a bulldozer blade. It must be lifted by the front-loading machine and tipped into place to form a desired stockpile height. The top and side surfaces of the stockpile must be formed so as to shed the rainwater.
- 4.7.10 It is noted that during decommissioning it is anticipated that the permanent development at the Block Valve Stations, Theddlethorpe Facility (Option 2) and its associated access track would be removed and the land reinstated to its pre-development agricultural use.

Plate 3: Soil storage mound construction with excavators and dump trucks. Reproduced from Part 2: Sheet B of IoQ (2021) (Ref. 3).

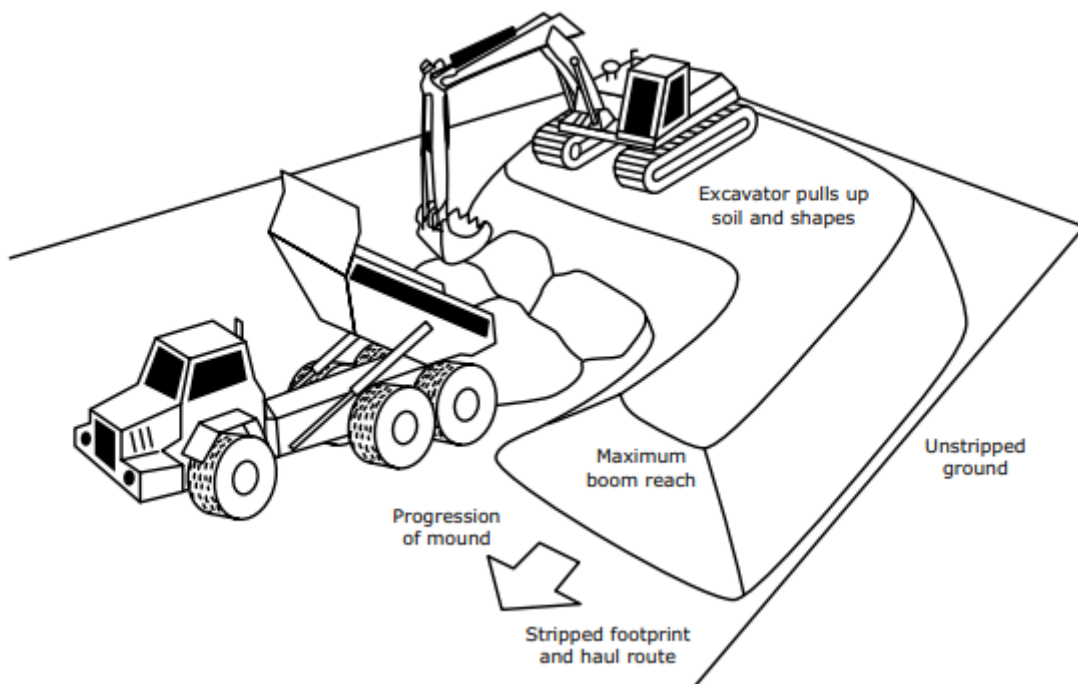

4.8 Stockpile Maintenance

- 4.8.1 Where soil is expected to be stored for a period of more than six months, the stockpiles should be seeded with appropriate low maintenance grass/clover mixture (for example EG22c Emorsgate Seed), or similar: to be agreed with landowner and subject to the conditions/restrictions within the contract; to protect the soil against erosion, minimise soil nutrient loss, and maintain soil biological activity. Appropriate seeding will also help prevent colonisation of the stockpile by nuisance weeds that could spread seed onto adjacent land.

- 4.8.2 In the period where vegetative cover on the stockpiles is establishing, where required during dry weather, the stockpiles will be sprayed with water to prevent wind erosion (generation of dust) and to ensure that the seeds establish.
- 4.8.3 Stockpiles will be monitored for the presence of undesirable weed species and the stockpile vegetation cover is to be managed (by spraying, mowing or stripping as appropriate and as defined in location-specific construction method statements, or similar), to prevent the spread of seeds from the stockpile onto adjacent land. Biosecurity measures are further discussed in *ES Volume IV: Appendix 3.1 Draft CEMP (Application Document 6.4.3.1)*.
- 4.8.4 Where soil will be stored for a shorter period than six months, they may not require seeding. However, weather conditions and soil sensitivity to erosion and should be considered, and appropriate measures put in place to reduce soil erosion where necessary.
- 4.8.5 The condition of all stockpiles is to be regularly monitored. If rainwater gathers on the stockpile surface or in areas directly adjacent to them, drainage pathways to soakaway areas away from the stockpile should be provided.

4.9 Stockpile Records

- 4.9.1 The locations and footprints of each stockpile should be accurately recorded on a plan of appropriate scale. Each stockpile should be assigned a unique identifier code, so that records regarding the stockpile are clearly traceable and distinguishable from those of other stockpiles. Marker posts should be provided in locations which have been surveyed and recorded; marker posts should display the stockpile identifier code.
- 4.9.2 The approximate volume of each (uniquely identified) stockpile should be recorded, along with details of the type of soil stored and the location from which the soil was stripped, which will allow cross reference with the detailed soil survey data if required.
- 4.9.3 The detailed SMP will contain a soil balance.
- 4.9.4 Regular inspections of the stockpiled soils should be undertaken, particularly of soils that are highly sensitive and/or at a greater risk of erosion – see **Table 4**. The spatial extent of soil associations susceptibility is indicated in **Figure 1** and described in *ES Volume II Chapter 10: Agriculture and Soils (Application Document 6.2.10)*. If signs of erosion are observed then reforming the sides of the stockpile or implementing additional mitigation measures may be required, as described in Section 4.7.
- 4.9.5 The growth of trees and scrub on the long-term soil stockpiles required for soils from the Block Valve Station, Theddlethorpe Facility Option 2 and its access road should be prevented as the development of tree roots and stumps can hinder the later reuse of the soils.

4.10 Access along pipe trenches

- 4.10.1 Where access is necessary along pipe trenches, suitable soil preparation to create a stable working area for temporary haul roads while minimising soil degradation should be undertaken. This may include measures such as soil stabilisation, soil stripping and temporary trackways being created. The subsoil may in some instances be used as the surface of temporary haul roads within the proposed working area. Pre-construction surveys should inform the subsoil bearing capacity on a location-by-location basis. Whilst it is likely subsoils along the pipeline route will have a moderate to high bearing capacity, ‘bog mats’ or stone tracks may be required where the subsoil bearing capacity is not sufficient to support the construction vehicles.

4.11 Drainage

- 4.11.1 Prior to soil stripping, where required, pre-construction drainage will be installed per specification provided by a specialist drainage contractor. This drainage is designed to prevent water entering the working area.
- 4.11.2 Gaps shall be left between soil stockpiles where necessary to allow for surface water drainage and avoid the catchment (ponding) of water behind stockpiles. In certain areas (as defined in location-specific construction method statements or similar) 'grips' may be dug across the working area at predetermined locations to prevent erosion and prevent ponding against stockpiles. Appropriate measures such as stones, silt traps and silt fencing should be employed as required.

4.12 Restoration

- 4.12.1 The contractor would clear all temporary working areas and accesses as the work proceeds, and when they are no longer required for the works. On completion of the construction works, all plant, materials and temporary works/structures would be removed.
- 4.12.2 Most of the land disturbed as a consequence of the Proposed Development will be restored to its original land use; however, it is noted that some areas will be restored to a different land use (for example landscaped areas adjacent to Block Valve Stations). In most locations, direct excavation of the soil from the stockpiles using a long-reach backacting/360° excavator will be possible.
- 4.12.3 Where larger stockpiles are created and there is a necessity for soils to be transported to the reinstatement area via dump truck, for example at the temporary construction compounds, stockpile excavation is to follow the methodology described in IoQ Guide, Part 2, Sheet C: Excavation of Soil Storage Mounds with Excavators and Dump Trucks (Ref. 3). In this method, the dump trucks enter the storage area travelling on the base layer (where topsoil and subsoil stripped) and on the subsoil (where only topsoil stripped). If back-acting/360° excavator is used it must stand on top of the stockpile to load the dump truck (see **Plate 4**). The stockpile is dug to the base (the original subsoil) before moving progressively back along its axis.
- 4.12.4 The main objective for the restoration of agricultural land is to reinstate the land to its original (pre-development) Agricultural Land Classification (ALC) grade. This is primarily achieved by ensuring that the full soil profile is restored in the correct sequence of horizons, and in a state where good soil profile drainage and plant root development are achieved; and by ensuring that the reinstatement works cause minimum damage to soil structure. As stated in paragraphs 1.1.6 and 4.1.4 of this document, pre-commencement soil and ALC surveys will incorporate all land which will be subject to direct disturbance. The soil survey data will record details of the pre-development soil profiles and these data will be used to describe the proposed restoration profiles in the detailed SMP, with the proposed restoration profiles matching the original profiles. Whereas the ALC data will provide the baseline against which the quality of the restored agricultural land will be measured.
- 4.12.5 Therefore, soil restoration has been designed to achieve soil profiles as close to the original (pre-construction) as possible, which is a prerequisite for the maintenance of the original agricultural land quality/other prior land use.
- 4.12.6 Post-construction soil surveys will be required across all land reinstated to agriculture, to determine whether target soil profile specifications have been met, and post-construction ALC survey will determine the land quality achieved, this is further described in paragraphs 4.12.17 to 4.12.20.

4.12.7 In areas where land compaction has occurred, or where required by the landowner, it may be necessary to undertake subsoil restoration techniques to restore the structure of the subsoil and to assist with future drainage. Topsoil would be returned to its final location at the earliest suitable time of year. The topsoil would be levelled, cultivated and reseeded as agreed with the landowner/occupier.

**Plate 4: Excavation of soil storage mound with excavators and dump trucks.
Reproduced from Part 2: Sheet C of IoQ (2021) (Ref. 3).**

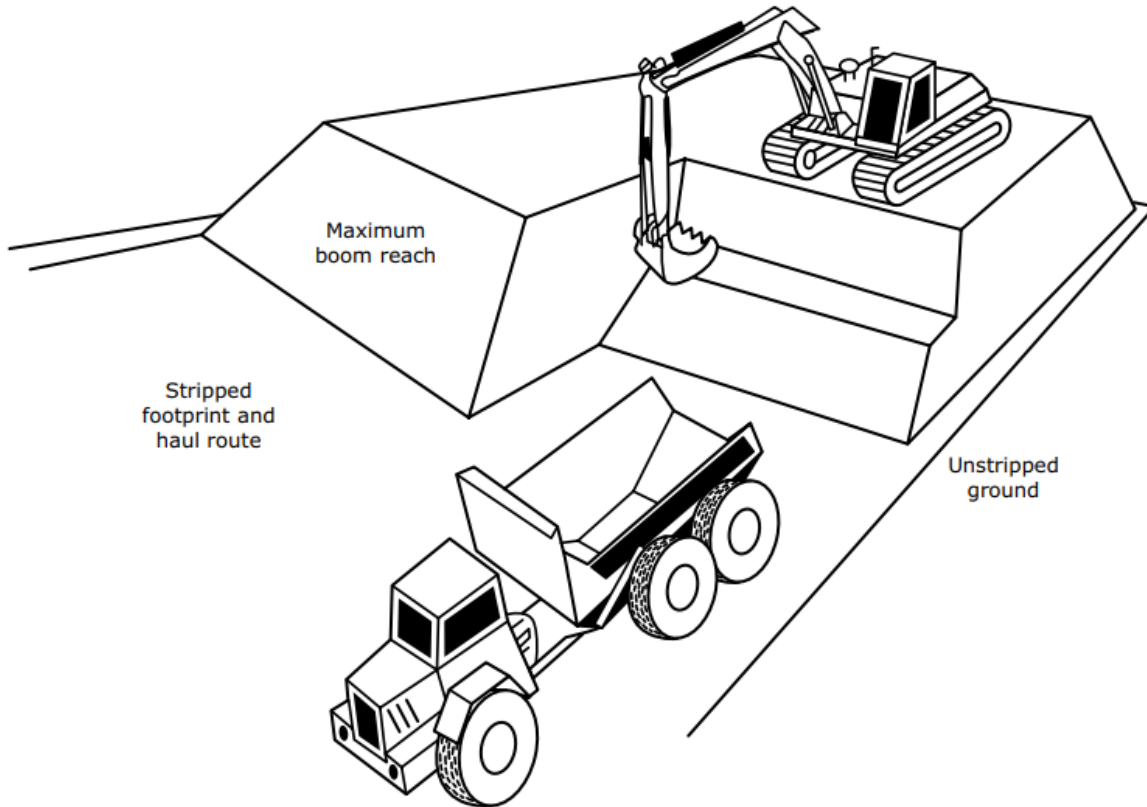

General methods to be used during restoration

4.12.8 Soil reinstatement shall be subject to the same constraints of weather and soil moisture conditions as soil stripping. All methods must adhere to the general principles set out below.

Excavation of soil stockpiles

4.12.9 The size of the earthmoving plant to be used should be tailored to the size of the area to be reinstated. Front loading machines may be used, in which case they will not need to enter the top of the stockpile. Any exposed edges/surfaces should be shaped at the onset of rain and at the end of each day.

Placement of excavated materials

4.12.10 Where restoration involves the replacement of excavated materials other than soils (i.e. material (overburden) from a depth greater than the base of the subsoil); the overburden must be replaced first. The overburden material may be overfilled by 10 to 15 % to allow for settlement to the design profile.

4.12.11 Following the placement of overburden to form the base layer, where required, the surface should be graded to the required landform and any debris removed before soils are

reinstated. Similarly, where required, the surface of the overburden should be loosened to an appropriate depth of not greater than 1.2.m.

Soil reinstatement

- 4.12.12 Soil reinstatement is the reverse of soil stripping with topsoil being replaced over subsoil. The specifications for reinstated soil profiles are to be determined on a location-by-location basis using the soil survey data; and set out in location-specific construction method statements. Care must be taken to ensure that soil horizons are replaced to the correct thickness (with an allowance of up to 20% to allow for settlement).
- 4.12.13 In most locations, direct excavation and restoration of the soil from the stockpiles using a long-reach back-acting/360° excavator will be possible. In this method, the subsoil will be replaced first, with the excavator travelling on the subsoil and gradually taking the topsoil from the stockpile and depositing it on the subsoil. The deposition is to be carried out by loose tipping and a toothed digger bucket is to be used.
- 4.12.14 Soil replacement is to follow the methodology set out in IoQ Guide, Sheet D: Soil Replacement with Excavators and Dump Trucks (Ref. 3). In this method, the soil is replaced in strips above the base layer to recreate the original soil profile. The topsoil is replaced on the previously decompacted subsoil. The replacement is carried out in strips in a similar manner to the stripping operations. First, the initial strip width and axis is to be demarcated. The width of the strip is determined by excavator boom length less the stand-off to operate; typically, 5 to 8 m. A wide bladed bucket should be used to spread the soil (use of a toothed bucket must be avoided in this case).
- 4.12.15 The dump truck should reverse to the edge of the current strip and tip the lowest layer, without the wheels riding onto the strip. The dump truck must not drive away until all the soil is deposited within the strip without spillage over the basal layer. To achieve this, assistance from the excavator to 'dig away' some of the tipped soil may be required. The tipped soil should be spread to the full thickness required, by the excavator utilising the digging, pushing and pulling action of the bucket. Each load must be spread before another is tipped. Repeat the process along the strip until it is completely covered with the required depth of the soil layer. Should the spread soil comprise of large blocks (greater than 0.3 m), they should be broken down by 'slicing' them with the excavator bucket.

Soil decompaction

- 4.12.16 Due to the use of subsoil as the working surface, subsoil decompaction will be required prior to the placement of the topsoil, with depth of decompaction reflecting the depth of compaction so that the compacted layer is fully removed. The decompaction method using a low ground pressure bulldozer either fitted or towed with winged subsoiler tines is recommended; and further details will be provided in the detailed SMP based upon measures set out in Sheet O: Soil Decompaction by Bulldozer Drawn Tines, of the IoQ guidance (Ref. 3). If required, for example on steep and/or complex landforms where use of a tined subsoiler is not possible, the detailed SMP will set out an alternative decompaction methodology based upon Sheet N: Soil Decompaction by Excavator Bucket, of the IoQ guidance (Ref. 3). For the decompaction to be effective, the moisture content of the soil must be below the lower plastic limit, so that the soil is dry enough to shatter and for fissures to be created. As the soil in the trench is to be deposited through loose tipping (see earlier section), no ripping of the trench area will be required. Further information on the issues surrounding soil compaction can be found in the IoQ Guide: Supplementary Note 3 – Compaction (Ref. 3).

Achieving the restoration standard

- 4.12.17 The quality of the soil reinstatement will need to be verified by the ALO/Land Officer or TSA as described in Section 1.3. Post-restoration surveys will be required across all land

reinstated to agriculture, to determine whether target soil profile specifications have been met. The aftercare will commence after soil characteristics achieve the restoration standard.

- 4.12.18 It is anticipated that the appointed Contractor will commission post-construction soil surveys to record the 'after' statement of physical characteristics of the restored soils.
- 4.12.19 This 'after' statement will be compared to the 'before' statement to verify that the land has been restored to the required standard (target soil profile specifications have been met). If the restored soil properties are found to differ from the 'before' characteristics to an extent that makes it impossible for the standard to be reached, the remediation will need to be carried out before the aftercare commences, for example, if further subsoil decompaction is required. This approach will ensure that any problems with the restoration of the soil resource are identified and rectified early after construction. This will in turn minimise the period of aftercare and risk of compensation claims.
- 4.12.20 It is noted that the physical conditions on restored land may take several years to stabilise; therefore, ALC survey is not normally undertaken (the land is not normally graded) until five-years after soil replacement (Ref. 10). However, despite the post-construction surveys occurring soon after reinstatement (well before the end of the five-year stabilisation period) calculation of ALC grading will be undertaken to compliment the post-construction soil surveys and provide an initial assessment of post-restoration ALC grading. It is expected that for most of the land surveyed these initial data will prove that the pre-construction ALC grading has been met; and it is noted that any change in ALC grading during the five-year stabilisation period would be expected to be an improvement (increase in grading).
- 4.12.21 For parcels where comparison of the pre- and post-construction survey data shows the original ALC grading to have been achieved, no further monitoring / ALC survey will be undertaken.
- 4.12.22 For parcels where comparison of the pre- and post-construction survey data shows the original ALC grading not to have been achieved by the time this initial assessment is undertaken, the land will be subject to further monitoring, for example after completion of any remediation work identified by the post-construction soil surveys, at intervals during the five-year stabilisation period until such time as the pre-construction ALC grading is shown to have been achieved. Details of the monitoring programme would be confirmed after the results of the post-construction soil and ALC surveys were known.

4.13 Aftercare

Responsibilities and content of the aftercare

- 4.13.1 The aftercare will be the responsibility of the Contractor, it will include treatments such as: cultivation (e.g. subsoiling), installation of underdrainage, seeding, liming and fertilising, as and when required. The aftercare programme is to be agreed between the Contractor, landowner, and (if applicable) tenant farmer. It will clearly define who is responsible for which part of the programme. For example, the Contractor may be responsible for initial soil testing (to determine lime and fertiliser requirements) and installation of drainage, the tenant farmer may be responsible for carrying out the cultivation and fertilisation.

Period of the aftercare

- 4.13.2 Due to the chance of differential settlement, a flexible period of aftercare of minimum one year is suggested, with the aftercare deemed complete when the restoration standard has been achieved. It will be the responsibility of the Land Officer/ALO or TSA, in discussions with landowners, to determine when the restoration standard has been met.

5 Biosecurity

- 5.1.1 During large-scale projects, there is the potential for disease and pathogen transfer between different areas of agricultural land (i.e. a biosecurity risk). The relocation of soil resource is considered as the main cause of disease and pathogen transfer, due to the transfer of soil (and incorporated seed/spore bank and pathogens) from infected to uninfected areas.
- 5.1.2 To minimise the biosecurity risk, including the potential transfer of disease, pathogens and weeds, the use of best practice measures, such as the good practice guidelines set out in Section 4 will minimise soil loss and soil movement through erosion, excess trafficking on plant wheels, or unauthorised export, for example.
- 5.1.3 In addition, to minimise biosecurity risks, appropriate cleaning and/or disinfection of machinery, equipment, clothing and footwear between holdings to mitigate against any disease outbreak or transfer of weeds between holdings may be required. This should be undertaken after working in areas considered to be at high risk before moving into uninfected areas. This is also particularly important for intensive pig and poultry units, cattle and any land with organic designations.
- 5.1.4 Section 4.8: Stockpile Maintenance, describes the management of nuisance weed species in stockpiles and prevention of seed spread.
- 5.1.5 UK Government's website advertising current occurrences and imposed restrictions with regards to animal and plant diseases (Ref. 11) should be checked by the appointed Contractor both pre-construction and at regular intervals throughout construction. The Contractor should also subscribe to the Animal Disease Alert Subscription Service. All restrictions will be adhered to and may include additional biosecurity measures being implemented such as restricted movements within prevention zones and additional measures around the disinfection of plant and equipment (including boots and manual tools).

6 Additional Mitigation and Enhancement Measures

- 6.1.1 Additional (bespoke) mitigation measures are required for soils identified as being at high risk of damage or erosion. Based upon the currently available data these are described in Section 3, and their spatial extent is described in **Figure 1**.
- 6.1.2 The detailed pre-construction soil survey data should be interrogated to define the extent of any soils at high risk of damage or erosion at the field level; allowing location-specific construction method statements (or similar) to be developed.
- 6.1.3 For the soils of the Salop association, the soil surveys will determine whether the soils are drained or not (noting that a worst case undrained state has been assumed). Where possible working of these soils should be undertaken in the driest possible conditions, and where required appropriate wet-working methods as described in Section 4 should be applied. Additionally, a site specific storage and drainage assessment should be undertaken in areas where sensitive soils are to be stored to:
- Ensure that the area is isolated from potential surface water loading from adjacent land or recommend additional drainage; and
 - Ensure bund design is sensitive to local site conditions (exposure, slope, underlying drainage capacity).

- 6.1.4 As stated previously, high erosion risk soils of the Sandwich association have been avoided by the design of the Proposed Development. However, other soils at high risk of erosion are identified during the soil surveys, the stockpiles should be formed and seeded as described Section 4. The stockpile may then be covered in with an appropriate geotextile to stabilise it until the vegetation cover becomes effective. Depending upon specific site and soil conditions, other bespoke mitigation measures for erosion sensitive soils will be expected to include, but not necessarily be limited to the use of specialist surface run-off control systems and wind barriers.
- 6.1.5 For soil storage, geotextiles that are permeable and biodegradable are recommended. This will prevent soil movement but allow for water and air to pass through maintaining soil in a good condition. A geotextile that is able to support plant rooting will be beneficial and able to aid stockpile stability and reduce erodibility.

Excavating stockpiles covered with geotextile

- 6.1.6 Gradually remove the geotextile from the stockpiles as the excavation progresses leaving enough to cover the end of the stockpile at the end of the working day (or during rain stoppage). Remove the geotextile off-site to a local green waste composting facility or other suitably licenced facility. It is expected that the amount of soil left on the geotextile will be minimal and will not result in significant loss of soil.
- 6.1.7 Should the geotextile be sufficiently decomposed and break into small (a few centimetres wide) fragments upon the removal, it can be left on the stockpile during the excavation and left in the reinstated soil. The suitability of this option should be assessed by the ALO/Land Officer.

7 Monitoring Schedule

7.1.1 **Table 4** summarises the need for record keeping and monitoring during the construction phase.

Table 4: Record keeping and monitoring during the construction phase

Item	What to look for	Responsibility	Frequency
Soil stockpiles	Erosion rills, water ponding, loss of protective vegetation or/and geotextile cover, invasive weeds	Contractor	Once a month and after rainfall exceeding 10 mm in 24 hrs.
Soil handling	Conformance with the SMP, record operations undertaken, weather and soil conditions, any problems and corrective actions undertaken.	Contractor	Daily.
	Conformance with the SMP, check daily record.	ALO/ Land officer	Varies, but at least once a week.
Verification of the restoration standard	Has the soil profile been restored to, as much as practicable to do so, a condition when last time used for agriculture?	ALO/ Land officer	Once, after reinstatement, re-inspected after remediation (if applicable).
Aftercare reports	Significant differences in crop performance, compaction and waterlogging between the restored and undisturbed land.	Operator	Annually until unrestricted agricultural use can commence.

7.1.2 It is expected that annual reports will be required during the aftercare period. The aftercare report will contain results of appropriate soil testing, the TSA will determine what tests are required and carry out the testing and record the soil condition. As a minimum the testing will comprise:

- Visual assessment of plant cover and ground surface; and
- A series of trial pits to assess the soil structure at depth and penetration by plant roots.

7.1.3 Non-conformance reporting, corrective actions, and incident responses are to be undertaken by the ALO according to the procedures described in the detailed CEMP.

8 References

Ref. 1 *Department of Environment, Food and Rural Affairs (DEFRA) (2009)*, Construction Code of Practice for the Sustainable Use of Soils on Construction Sites. Accessed: 03 May 2023. Available at: <https://www.gov.uk/government/publications/code-of-practice-for-the-sustainable-use-of-soils-on-construction-sites>

Ref. 2 *MAFF (2000)*. Good Practice Guide for Handling Soils. Available at <https://webarchive.nationalarchives.gov.uk/ukgwa/20090317221756/http://www.defra.gov.uk/farm/environment/land-use/soilguid/index.htm>

Ref. 3 *Institute of Quarrying (2021)*. Good Practice Guide for Handling Soils in Mineral Workings. Accessed 10 May 2023. Accessed 17 May 2023. Available at: <https://www.quarrying.org/soils-guidance>.

Ref. 4 *HM Government (2015)*. Construction (Design and Management) Regulations (CDM). Accessed 17 May 2023. Available at: <https://www.legislation.gov.uk/ukxi/2015/51/contents/made>

Ref. 5 *HM Government (1974)*. Health and Safety at Work Act, 1974. Available at <http://www.legislation.gov.uk/ukpga/1974/37/contents>

Ref. 6 *Institute of Environmental Management and Assessment (2022)*. A New Perspective on Land and Soil in Environmental Impact Assessment. (Not available online)

Ref. 7 *Cranfield University (2015)*. 'Research to develop the evidence base on soil erosion and water use in agriculture: Final Technical Report. pp147' Accessed 18 May 2023. Available at <https://www.theccc.org.uk/wp-content/uploads/2015/06/Cranfield-University-for-the-ASC.pdf>

Ref. 8 *Cranfield University 2023*. The Soils Guide. Accessed 11 May 2023. Available at: www.landis.org.uk.

Ref. 9 *Met Office (1989)*. Climatological Data for Agricultural Land Classification (ALC): Grid point datasets of climatic variables at 5 km intervals for England and Wales. Accessed 10 May 2023. Available at: <https://data.gov.uk/dataset/8a334958-ff65-4f5c-9674-5a85e61ee269/climatological-data-for-agricultural-land-classification>

Ref. 10 *MAFF (1988)* 'Agricultural Land Classification of England and Wales: Revised guidelines and criteria for grading the quality of agricultural land'. Available at: <http://publications.naturalengland.org.uk/publication/6257050620264448>

Ref. 11 Defra's Animal and Plant Health Agency website. Available at <https://www.gov.uk/government/organisations/animal-and-plant-health-agency>